



ⓘ **INTERSTEEL**
Exclusives

Signature: **Sliced**
Arjan Moors



Signature: **Sliced** *Arjan Moors*



2013 ■

Arjan Moors is een professional die zijn sporen in de (design) meubelindustrie heeft verdiend. Hij is niet alleen productontwerper maar leverde ook de input voor internationale beursstands. Arjan haalt zijn energie en inspiratie uit de eenvoud van het alledaagse. Naast een afgeronde productontwerpstudie aan de Design Academie Eindhoven heeft hij gestudeerd aan de Kunstacademie Maastricht. In 2013 viel hem een felbegeerde IF Design award ten deel voor een drietal deurkrukken (kruk no. 2, no. 4 en no. 5) voor INTERSTEEL.

Arjan Moors is a design professional who has certainly earned his reputation in the (design) furniture industry. He is not just a product designer but also provides input for international trade fair stands. Arjan derives his energy and inspiration from the simplicity of the everyday. As well as completing a product design course at the Design Academy Eindhoven, he studied at the Maastricht Academy of Fine Arts and Design. In 2013 he was awarded the highly coveted IF design award for three door handle designs (handles no. 2, no. 4 and no. 5) for INTERSTEEL.



No. 1



0035.072302



0035.072202



0036.072302



0036.072202





No. 2



0035.072702



0035.072602



0036.072702



0036.072602





No. 3



0035.072102



0035.072002



0036.072102



0036.072002





No. 4

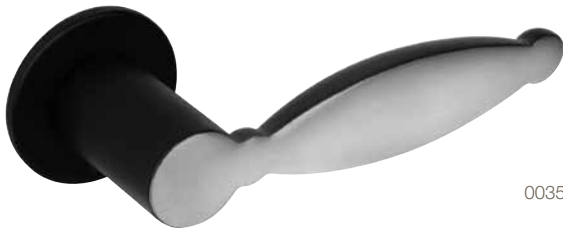

0035.072902



0035.072802



0036.072902



0036.072802





No. 5



0035.072502



0035.072402



0036.072502











0036.072402









Veiligheidsschilden - Security plates

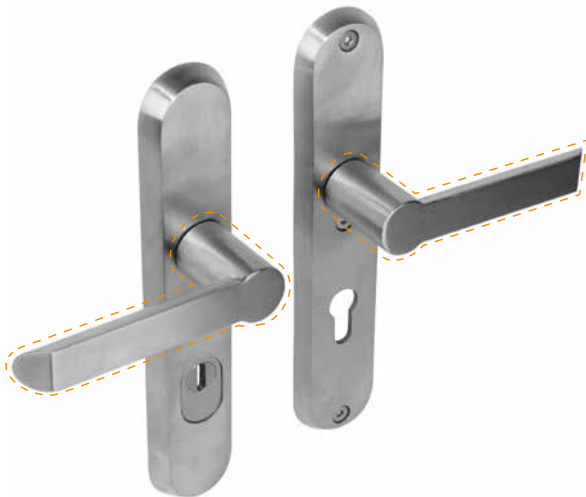

🔑	🔑	Ⓛ	Ⓡ	—
72mm	0035.396036 +			0035.072602A
92mm	0035.396049 +			0035.072602B
				0035.072802A
				0035.072802B











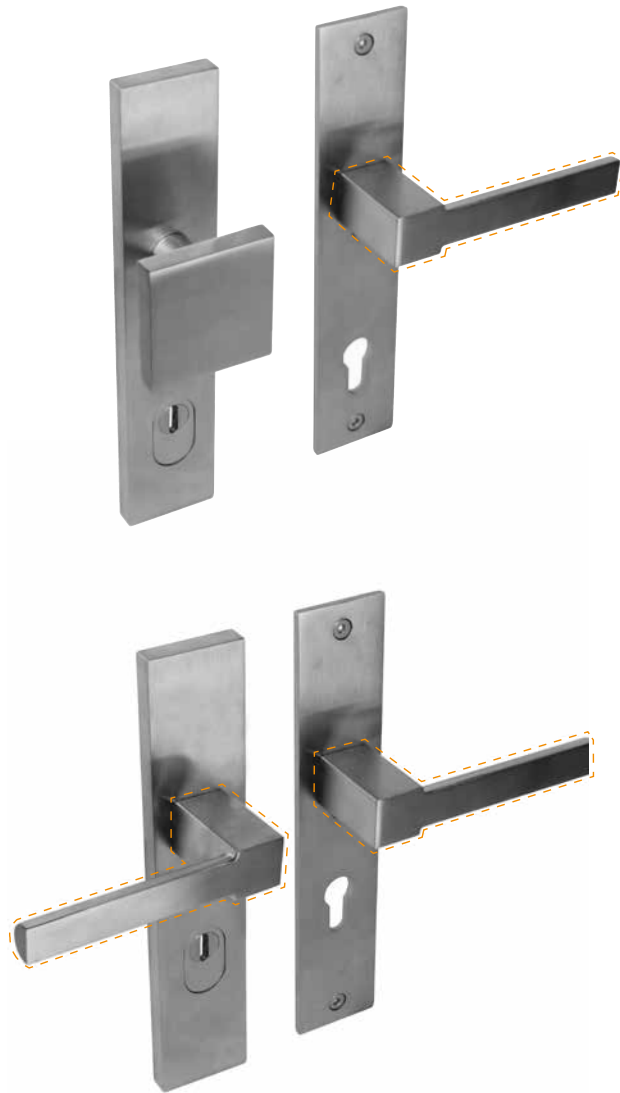









🔑	🔑	Ⓛ	Ⓡ	—
72mm	0035.396136 +			0035.072602
92mm	0035.396149 +			0035.072802















Veiligheidsschilden - Security plates



				
72mm	0035.396236 +			0035.072202A
92mm	0035.396249 +			0035.072202B
				0035.072002A
				0035.072002B
				0035.072402A
				0035.072402B

				
72mm	0035.396336 +			0035.072202
92mm	0035.396349 +			0035.072002
				0035.072402





No. 1



De kunst van het weglaten. Zo zou Japans minimalisme, waar kruk no. 1 op geïnspireerd is, het best omschreven kunnen worden. 'Less is Moors'. Kenmerkend is de Japanse werkwijze door met drie sneden de kruk af te maken. De kruk is uitgevoerd in massief RVS en verkrijgbaar in vier finishes met losse rozet zonder veer.

The art of elimination. This is how Japanese minimalism, which provided the inspiration for handle no. 1, could best be described. 'Less is Moors'. The handle, with its three edges, is characterised by the Japanese method. The handle is manufactured in solid stainless steel and is available in four finishes with separate rose unsprung.

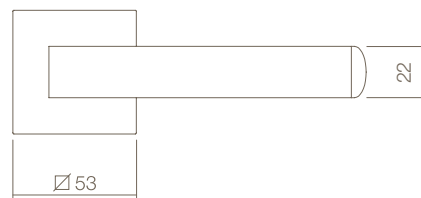
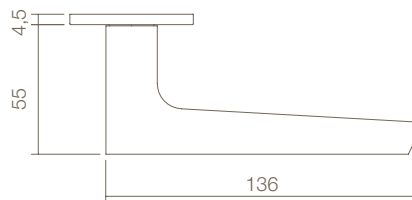

RVS geborsteld
brushed stainless steel
0035.072202

mat zwart RVS geborsteld
satin black brushed stainless steel
0035.072302

RVS gepolijst
polished stainless steel
0036.072202

mat zwart RVS gepolijst
satin black polished stainless steel
0036.072302

No. 2

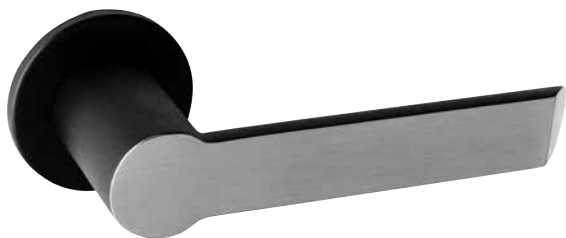

De basis voor deze deurkruk zijn minimalistische vormen die sterk aan 'Bauhaus Design' doen denken. De ontwerper voegt subtiel twee basisvormen samen en laat deze door de snede aan de voorzijde samenvloeien tot één vorm. Afhankelijk van de kleurstelling wordt deze snede geaccentueerd door de afwijkende finish. De kruk is uitgevoerd in massief RVS en verkrijgbaar in vier finishes met losse rozet zonder veer.

This door handle is based on minimalist forms that are highly reminiscent of 'Bauhaus Design'. The designer subtly combines two basic shapes and uses the front edge to fuse them into a single form. Depending on the colour this edge is accentuated by the different finish. The handle is manufactured in solid stainless steel and is available in four finishes with separate rose unsprung.

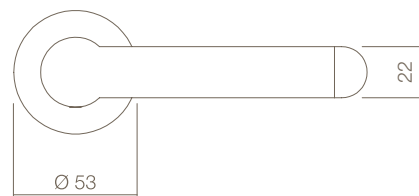
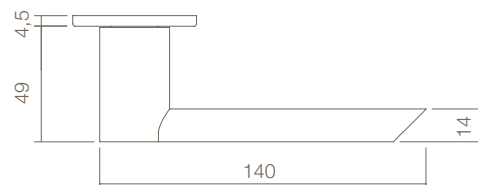

RVS geborsteld
brushed stainless steel
0035.072602

mat zwart RVS geborsteld
satin black brushed stainless steel
0035.072702

RVS gepolijst
polished stainless steel
0036.072602

mat zwart RVS gepolijst
satin black polished stainless steel
0036.072702

No. 3

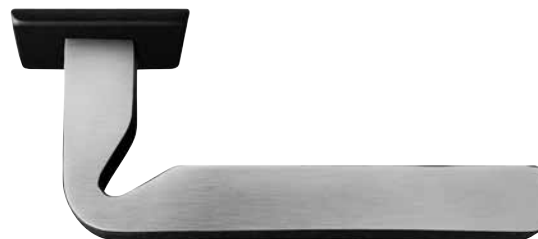

Dit ontwerp is geïnspireerd op een gebogen, metalen staf met een vierkante doorsnede. De knik die door het buigen ontstaat, accentueert hij subtiel door de inham. De kruk is uitgevoerd in massief RVS en verkrijgbaar in vier finishes met losse rozet zonder veer.

This design is inspired by a curved metal rod with a square profile. The designer uses the indent to subtly accentuate the curve created by bending the material. The handle is manufactured in solid stainless steel and is available in four finishes with separate rose unsprung.

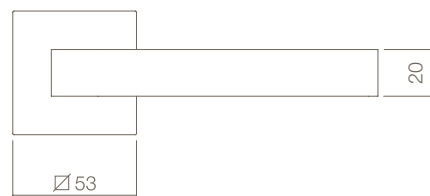
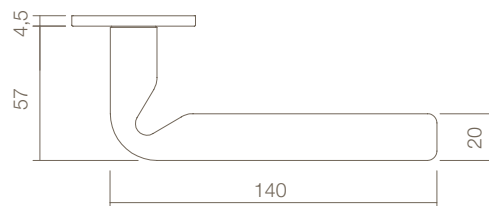

RVS geborsteld
brushed stainless steel
0035.072002

mat zwart RVS geborsteld
satin black brushed stainless steel
0035.072102

RVS gepolijst
polished stainless steel
0036.072002

mat zwart RVS gepolijst
satin black polished stainless steel
0036.072102

No. 4

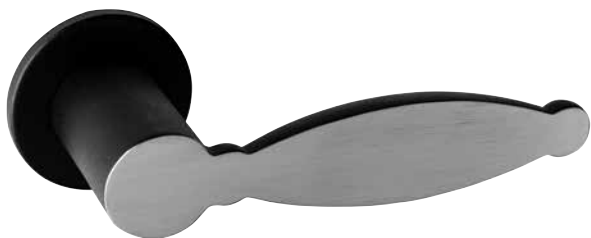

Kruk no. 4 in de Moors-collectie is een subtiele knipoog naar het verleden. Opnieuw gebruikt de ontwerper een snede om de verschillende vormen tot een eenheid te smelten. De kruk is uitgevoerd in massief RVS en verkrijgbaar in vier finishes. met losse rozet zonder veer.

Handle no. 4 in the Moors collection is a subtle reference to the past. The designer once again applies an edge to blend the different shapes into a single form. The handle is manufactured in solid stainless steel and is available in four finishes with seperate rose unsprung.

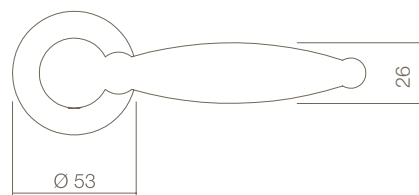
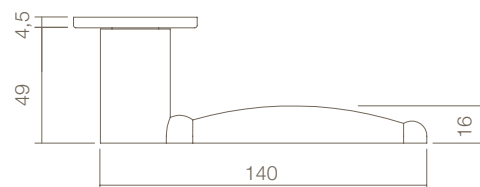

RVS geborsteld
brushed stainless steel
0035.072802

mat zwart RVS geborsteld
satin black brushed stainless steel
0035.072902

RVS gepolijst
polished stainless steel
0036.072802

mat zwart RVS gepolijst
satin black polished stainless steel
0036.072902

No. 5

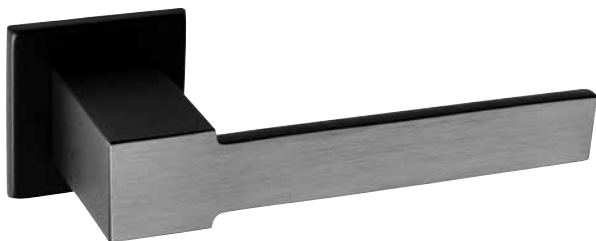

Kruk no. 5 is de vierkante variant van kruk no. 2. Door de ronde achterkant van de greep heeft ook deze kruk een ergonomische grip. Qua ontwerp doet kruk no. 5 sterk denken aan de zeer populaire ontwerpen uit de 'Bauhaus' periode. De kruk is uitgevoerd in massief RVS en verkrijgbaar in vier finishes met losse rozet zonder veer.

Handle no. 5 is the square version of handle no. 2. The rounded rear edge of the handle also offers it an ergonomic grip. In terms of design handle no. 5 is highly reminiscent of the extremely popular designs from the 'Bauhaus' period. The handle is manufactured in solid stainless steel and is available in four finishes with separate rose unsprung.

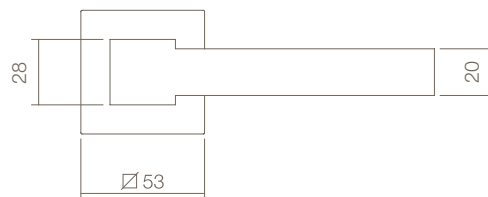
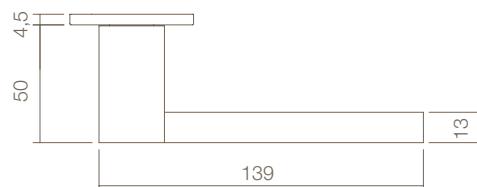

RVS geborsteld
brushed stainless steel
0035.072402

mat zwart RVS geborsteld
satin black brushed stainless steel
0035.072502

RVS gepolijst
polished stainless steel
0036.072402

mat zwart RVS gepolijst
satin black polished stainless steel
0036.072502

Accessoires - Accessories



0035.343116

0035.343117

0035.343160



0035.343316

0035.343317

0035.343360



0035.341316

0035.341317

0035.343060



0035.343216

0035.343217

0035.343260



0036.341316

0036.341317

0036.343060



0036.343216

0036.343217

0036.343260

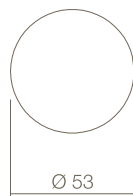

RVS geborsteld
brushed stainless steel

mat zwart RVS geborsteld
satin black brushed stainless steel



RVS gepolijst
polished stainless steel

Veiligheidsschilden - Security plates

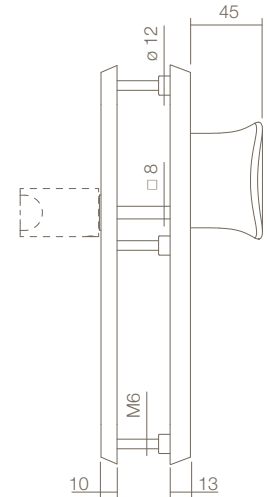
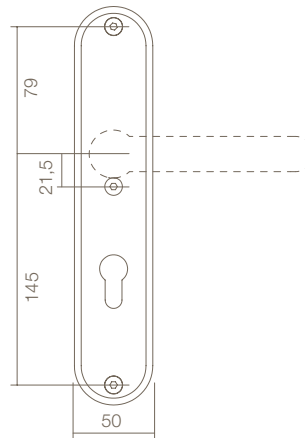
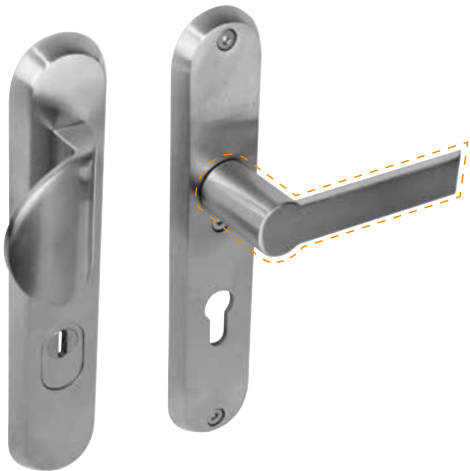

Veiligheid en design komen samen door deze subtiële ovale veiligheidsschilden met de design modellen te combineren. Massief roestvast staal in mooi afgewerkte vormen benadrukken de elementen van de INTERSTEEL by Arjan Moors modellen. De serie veiligheidsschilden is uitgevoerd volgens het SKG *** veiligheidskeurmerk. Een hoogwaardige oplossing en een maximaal gevoel van veiligheid.

'Safety' and 'design' combined. Oval security plates with design door handles. Brushed stainless steel with subtle designed shapes emphasize the Range of the INTERSTEEL by Arjan Moors handles. Approved by SKG *** for maximum safety.

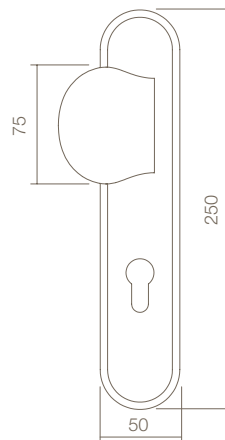

RVS geborsteld
brushed stainless steel

Veiligheidsschilden - Security plates

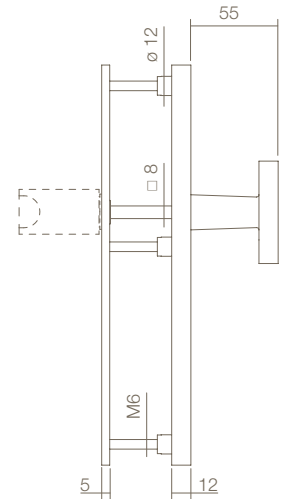
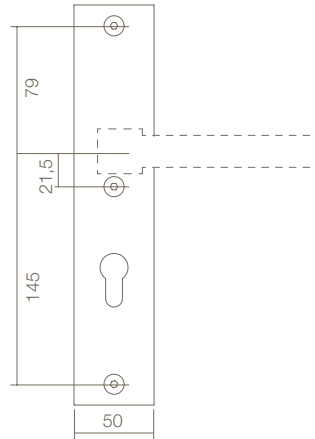
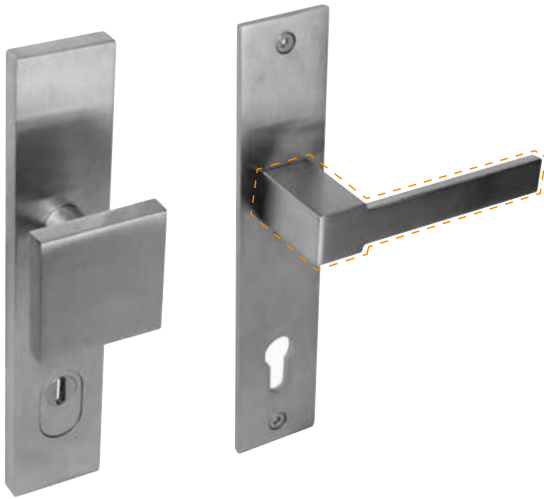

Roestvast stalen veiligheidsschilden in een rechthoekige vorm maken de serie binnen- en buitendeurbeslag INTERSTEEL by Arjan Moors compleet. De strakke vormgeving biedt prima combinatie mogelijkheden bij de deurkruk modellen en benadrukken de design ideeën van de ontwerper. Een optimaal gevoel van veiligheid en een zeer exclusieve uitvoering passend bij de gekozen deurkrukmodellen.

The rectangular security plates complete the INTERSTEEL by Arjan Moors Range. The sleek design can be easily combined with the different door handles. Maximum safety with the look and feel of exclusive design.

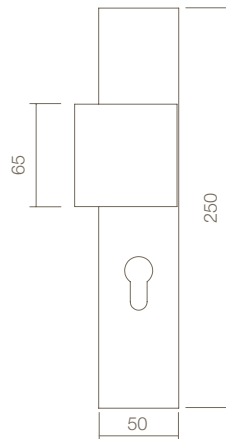

RVS geborsteld
brushed stainless steel







Intersteel • Utrechtsestraatweg 220 • NL-3911 TX Rhenen • P.O. Box 128 • NL-3910 AC Rhenen • The Netherlands
T +31 (0)318 - 47 77 77 • **F** +31 (0)318 - 47 77 78 • **E** info@intersteel.nl • **W** www.intersteel.nl

